



PERFORMANCE DATA SHEET

Meets or exceeds MEPS, as described by the US DOE in docket 10CFR431 and NRCAN's Amendment 14

Catalogue #: **MQS-346L**

HP	kW	Voltage	S.F. @ 60Hz	Efficiency	Power Factor	Frame	Design	L.R. Amps
0,75	0,56	230 / 460	1,15	81,7%	0,660	56C	B	15

60 Hz								
FLA							Code	F.L. RPM
208	230	416	460	480	575	600		
/	2,6	/	1,3	/	/	/		

50 Hz								
FLA			S.F. @ 50Hz	Efficiency	Power Factor	Code	F.L. RPM	
190	380	415						1,00
3,0	1,5	/						

Wgt. Lbs	PH	Duty	Insul. Class	Amb.	Elevation	Temp. Rise° C
34	3	Cont.	F	40°C	1000M (3300 Ft)	< 80

% Efficiency		% Power Factor		Torque		Winding Resist. Ω	Safe Cold Start (Secs)
Full Load:	81,7%	Full Load:	0,66	Full Load Ft/Lbs	3,4		
3/4 Load:	71,5%	3/4 Load:	0,58	Locked Rotor %	250		
1/2 Load:	58,1%	1/2 Load:	0,53	Break Down %	276		

Rotor Inertia Wk2 Lb-Ft2	Max Load Inertia Wk2 Lb-Ft2	Shaft Material	Frame Material	DE Bracket Type	ODE Bracket Type	Enclosure	NEMA Rating	Lead Wire Size
/	/	304SS	Stainless Steel			TENV	IP69K	16AWG

Ball Bearings		Grease	Mount Type	Orientation	Paint	Sound Pressure @ 3FT	Sound Power
DE	ODE						
6205	6205	Sealed Bearings	Foot	Horizontal	-	/	/

Inverter Duty. Motor meets MG1 parts 31.4.4.2	Constant Torque Range	Variable Torque Range	Constant HP RPM
		10:1	20:1

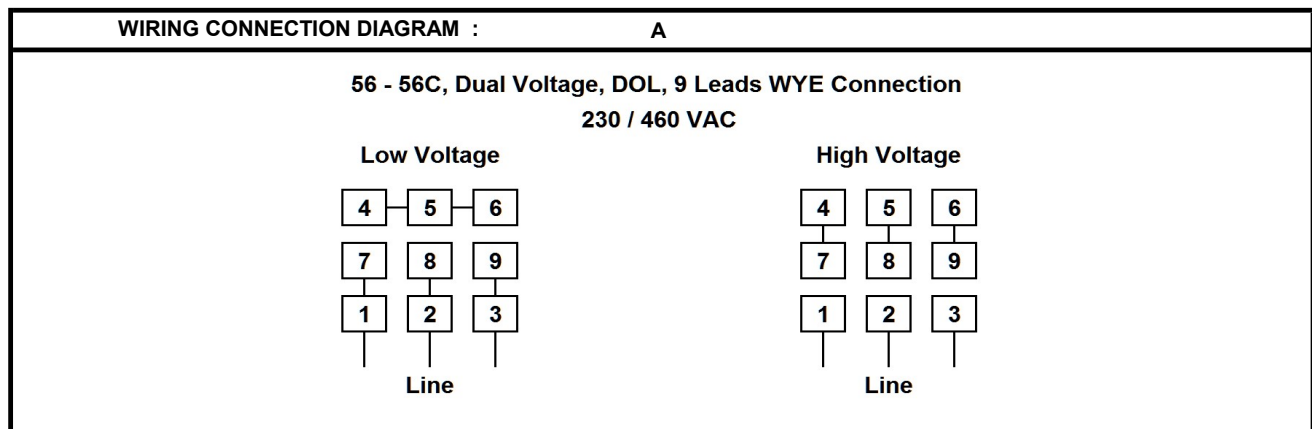

Date: 2024-01-29
 Customer: _____
 Contact: _____
 Submittee: J.C. Lavallée

Catalogue #: **MQS-346L**

Meets or exceeds MEPS, as described by the US DOE in docket 10CFR431 and NRCan's Amendment 14

HP	VAC	RPM	Enclosure	Frame	Frequency	Design	Poles	LR Code Letter	Insulation Class	Temp. Rise °C
0,75	460	1155	TENV	56C	60	B	6	K	F	< 80

	0Hz	6Hz	15Hz	30Hz	45Hz	60Hz	75Hz	90Hz	105Hz	120Hz
Amps	1,3	1,3	1,3	1,3	1,3	1,3	1,3	1,3	1,3	1,3
RPM	0	115,5	288,75	577,5	866,25	1155	1443,75	1732,5	2021,25	2310
Torq ft.lb	2,73	2,73	3,41	3,41	3,41	3,41	2,73	2,27	1,95	1,71
Peak Tq ft.lb	4,06	8,12	8,12	8,12	8,12	8,12	6,49	5,41	4,64	4,06
HP	0	0,1	0,2	0,4	0,6	0,8	0,8	0,8	0,8	0,8

	Locked Rotor	Pull-Up	Breakdown	Rated Load	Idle	Duty	S. F.	Ambient	Elevation	dBa @ 1M
Speed (RPM)	0,0	504	960	1155	1200	Continuous	1,15	40°C	3,300 ft	/
Current (Amps)	15,0	12,8	8,9	1,3	0,9	VFD Rating: Meets MG1 parts 31.4.4.2				
Torque (ft-lbs)	8,5	7,2	9,4	3,4	0,0	CT :	10:1	VT :	20:1	

Motor Speed Data

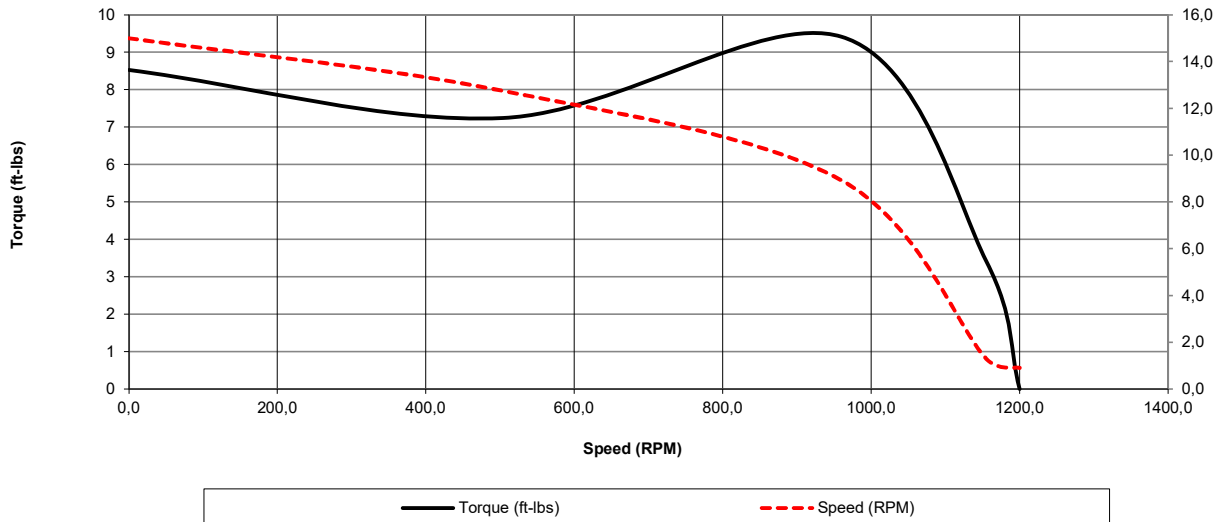

Motor Torque Capability vs RPM

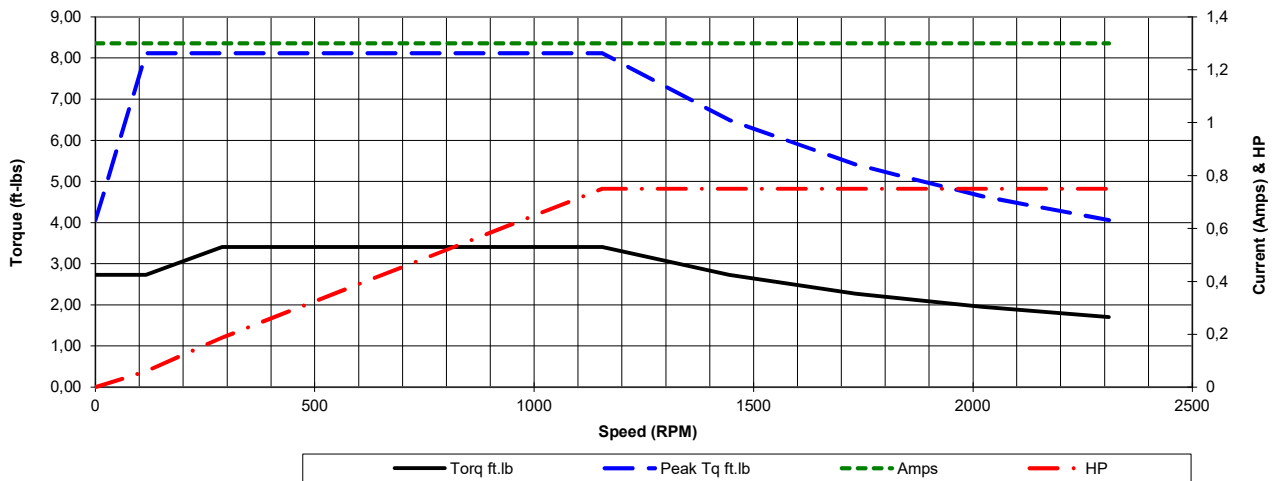

Date: 2024-01-29
 Customer: _____
 Contact: _____
 Submittee: J.C. Lavallée

Catalogue #: **MQS-346L**

Meets or exceeds MEPS, as described by the US DOE in docket 10CFR431 and NRCan's Amendment 14

HP	VAC	RPM	Enclosure	Frame	Frequency	Design	Poles	LR Code Letter	Insulation Class	Temp. Rise °C
0,75	460	1155	TENV	56C	60	B	6	K	F	< 80

Load %	0%	25%	50%	75%	100%	125%	150%
Amps	0,91	0,99	1,05	1,14	1,30	1,63	1,95
Torq ft/lbs	0	0,83	1,67	2,53	3,41	4,30	5,22
RPM	0	1188,75	1177,5	1166,25	1155	1143,75	1132,5
Eff	0	40,39	63,08	78,31	81,70	80,24	77,95
PF	0	44,0	52,8	59	66,0	67,3	69,3

	Locked Rotor	Pull-Up	Breakdown	Rated Load	Idle	Duty	S. F.	Ambient	Elevation	dBA @ 1M
Speed (RPM)	0	504	960	1155	1200	Continuous	1,15	40°C	3,300 ft	/
Current (Amps)	15	12,8	8,9	1,3	0,91	VFD Rating: Meets MG1 parts 31.4.4.2				
Torque (ft-lbs)	8,53	7,25	9,41	3,41	0,0	CT	10:1	VT	20:1	

